



**GET STARTED**



**LOADING #3**



### Toegang tot Get Started online

Voor de audio- en andere bestanden log je in op [app.schoolsupport.nl](http://app.schoolsupport.nl) via Basispoort, [toegangonderwijs.nl](http://toegangonderwijs.nl) of Entree.

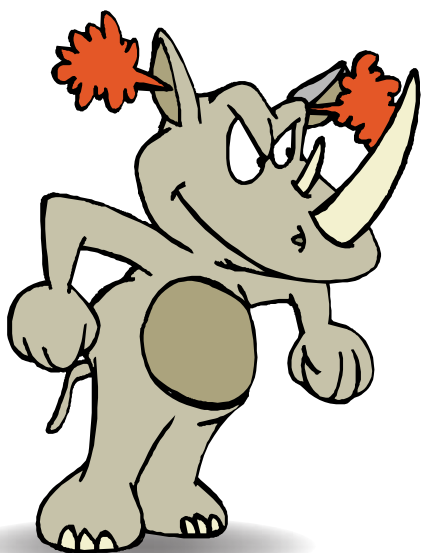

### GET STARTED #3

Auteur	Ron Riemens
Eindredactie	Schoolsupport
Vormgeving	Ron Riemens & Peggy Van Eyck
Omslagontwerp	Marino Pollet
Illustraties	© Hemera

© Uitgeverij Schoolsupport  
E: [service@schoolsupport.nl](mailto:service@schoolsupport.nl)  
[www.schoolsupport.nl/getstarted](http://www.schoolsupport.nl/getstarted)

© Schoolsupport bv. Alle rechten voorbehouden. Niets uit deze uitgave mag worden verveelvoudigd, opgeslagen in een geautomatiseerd gegevensbestand, of openbaar gemaakt in enige vorm of op enige wijze, hetzij elektronisch, mechanisch, of door fotokopiëren, zonder voorafgaande schriftelijke toestemming van de uitgever.

De uitgever heeft getracht de rechthebbenden van het illustratiemateriaal te achterhalen. Indien iemand meent dat rechten niet zijn gehonoreerd, dan kan hij of zij zich wenden tot de uitgever.



A crab, B lobster, C oyster D sea star

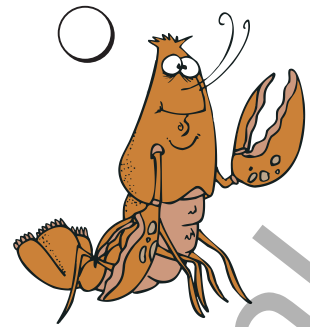
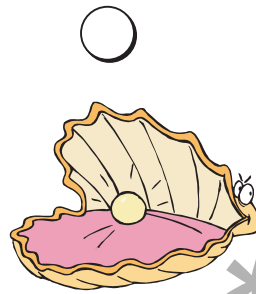
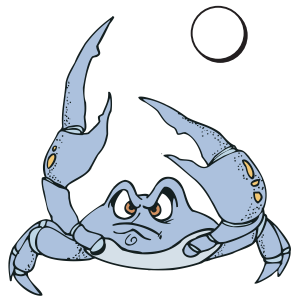
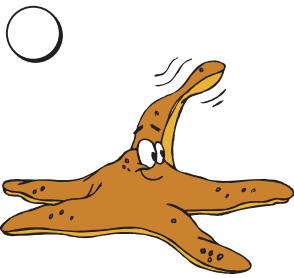

Match the words with their descriptions.

- |         |                            |   |
|---------|----------------------------|---|
| 1 ebb   | <input type="checkbox"/> S | A a large boat which carries passengers or cargo                  |
| 2 dune  | <input type="checkbox"/>   | D a piece of thick, soft material that you use to dry yourself    |
| 3 ship  | <input type="checkbox"/>   | E a hill made of sand near the sea                                |
| 4 shell | <input type="checkbox"/>   | I the land along the edge of a large area of water                |
| 5 shore | <input type="checkbox"/>   | S when the sea level on a coast becomes lower                     |
| 6 towel | <input type="checkbox"/>   | E a line of raised water that moves across the surface of the sea |
| 7 wave  | <input type="checkbox"/>   | S the hard protective covering of an animal such as a mussel      |

Underline the words that rhyme.

I'm a jellyfish  
yep, that's me  
I swim around  
completely free  
I prickle and sting  
maybe even you  
so if you see me  
you know what to do

How many words are there in the spiral?



- 11       12       13

Use the words in the box to complete the text.

brain, tentacles, crabs, their, made

- Jellyfish have no \_\_\_\_\_, heart, bones or eyes.
- They are \_\_\_\_\_ up of a smooth, bag-like body.
- The \_\_\_\_\_ are armed with tiny, stinging cells.
- They use them to stun or paralyse \_\_\_\_\_ prey.
- They eat plankton, fish, shrimp, \_\_\_\_\_ and tiny plants.

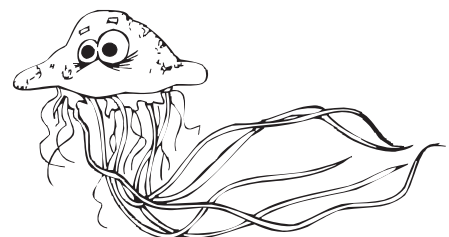



### Exercise 1 - Interview

Ask a classmate the following questions.

- 1 What games can you play on the beach?
- 2 Do you collect seashells?
- 3 What do you pack for a trip to the beach?
- 4 When did you last swim in the North Sea?
- 5 Why is it always windy at the beach?
- 6 What are the dangers of swimming in the sea?

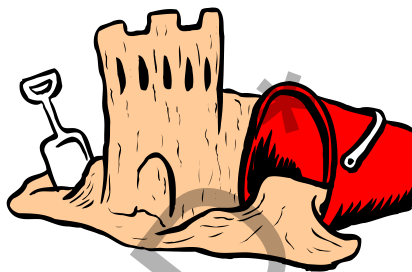

### Exercise 2 - Can you guess who I am?

Work together and try to solve these three riddles.

- |   |   |   |   |   |   |
|---|---|---|---|---|---|
| 1 | <p>I live in the sea.</p> <p>I eat oysters.</p> <p>I have five arms.</p> <p>I move very slowly.</p> | 2 | <p>I live in the ocean.</p> <p>I have eight legs.</p> <p>My body has a hard shell.</p> <p>My name starts with an L.</p> | 3 | <p>There are millions of me.</p> <p>I am very, very small.</p> <p>You don't want to eat me.</p> <p>Use me to make a castle.</p> |
|---|---|---|---|---|---|

### Exercise 3 - Talk about the pictures.

- 1 Take a look at these eight pictures.
- 2 What do you see?
- 3 Tell each other what is happening.

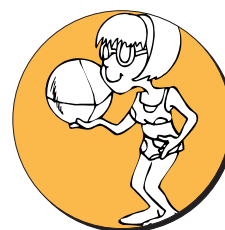

Write these seven words in alphabetical order.

always, auction, access, although, award, afraid, area

1	toegang	<input type="text"/>	<input type="text"/>	<input type="text"/>	<input type="text"/>	<input type="text"/>	<input type="text"/>	<input type="text"/>	<input type="text"/>	<input type="text"/>	1	<input type="text"/>		
2	bang	<input type="text"/>	<input type="text"/>	<input type="text"/>	<input type="text"/>	<input type="text"/>	<input type="text"/>	<input type="text"/>	<input type="text"/>	<input type="text"/>	<input type="text"/>	<input type="text"/>	2	<input type="text"/>
3	hoewel	<input type="text"/>	<input type="text"/>	<input type="text"/>	<input type="text"/>	<input type="text"/>	<input type="text"/>	<input type="text"/>	<input type="text"/>	<input type="text"/>	<input type="text"/>	<input type="text"/>	3	<input type="text"/>
4	altijd	<input type="text"/>	<input type="text"/>	<input type="text"/>	<input type="text"/>	<input type="text"/>	<input type="text"/>	<input type="text"/>	<input type="text"/>	<input type="text"/>	<input type="text"/>	<input type="text"/>	4	<input type="text"/>
5	gebied	<input type="text"/>	<input type="text"/>	<input type="text"/>	<input type="text"/>	<input type="text"/>	<input type="text"/>	<input type="text"/>	<input type="text"/>	<input type="text"/>	<input type="text"/>	<input type="text"/>	5	<input type="text"/>
6	veiling	<input type="text"/>	<input type="text"/>	<input type="text"/>	<input type="text"/>	<input type="text"/>	<input type="text"/>	<input type="text"/>	<input type="text"/>	<input type="text"/>	<input type="text"/>	<input type="text"/>	6	<input type="text"/>
7	prijs	<input type="text"/>	<input type="text"/>	<input type="text"/>	<input type="text"/>	<input type="text"/>	<input type="text"/>	<input type="text"/>	<input type="text"/>	<input type="text"/>	<input type="text"/>	<input type="text"/>	7	<input type="text"/>

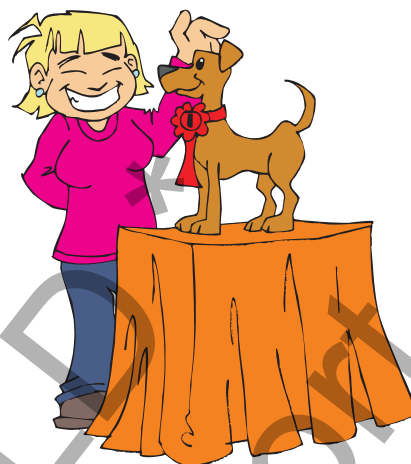

Write the orange words in the correct sentence.

- Jenny was \_\_\_\_\_ dressed in black.
- He got an \_\_\_\_\_ for his latest film.
- The ring was sold at an \_\_\_\_\_.
- I live in an \_\_\_\_\_ close to the city centre.
- She was never \_\_\_\_\_ of new adventures.
- \_\_\_\_\_ to the building is via the front door.
- \_\_\_\_\_ it rained, we had a good time.

Match the words with their translations.

3 to answer	belonen	6 to ask
1 to assist	vragen	4 to auction
aanvallen	veilen	antwoorden
helpen	5 to award	2 to attack

1 E 2 3 4 5 6

Use the words in the box to complete the text.

pay, diamonds, auction, much, will

- At an \_\_\_\_\_ people can buy or sell things.
- For example cars, paintings, \_\_\_\_\_ and electronics.
- People say how \_\_\_\_\_ they will pay for something.
- The person who wants to \_\_\_\_\_ the most gets it.
- The amount (money) people \_\_\_\_\_ pay is called a bid.

Cross out the double letters.



M	E	X	F	V	B
I	A	Q	P	N	Z
R	K	S	I	T	J
O	Z	F	C	A	D
V	D	U	P	R	T
K	X	Q	L	J	G
B	S	M	H	C	L

GOING ONCE, TWICE AND SOLD

Find the right translation and connect the dots.

- |                           |    |                   |   |                |
|---------------------------|----|-------------------|---|----------------|
| 1 ik begin                | ←→ | I begin           | ● | ● zij begonnen |
| 2 jij/u begint            | ←→ | you begin         | ● | ● het begon    |
| 3 hij/zij/het begint      | ←→ | he/she/it begins  | ● | ● wij beginnen |
| 4 wij/jullie/zij beginnen | ←→ | we/you/they begin | ● | ● jij begint   |
| 5 ik/jij/u/hij/het begon  | ←→ | I/you/he/it began | ● | ● ik begin     |
| 6 wij/jullie/zij begonnen | ←→ | we/you/they began | ● | ● het begint   |

Use the words to complete the sentences.

heard, spent, hid, were, began, lost

- I \_\_\_\_\_ some money on food.
- They \_\_\_\_\_ in Scotland for two weeks.
- She \_\_\_\_\_ herself behind some bushes.
- Hugo \_\_\_\_\_ his job three months ago.
- We never \_\_\_\_\_ from Nancy again.
- The space shuttle \_\_\_\_\_ its flight to the moon.

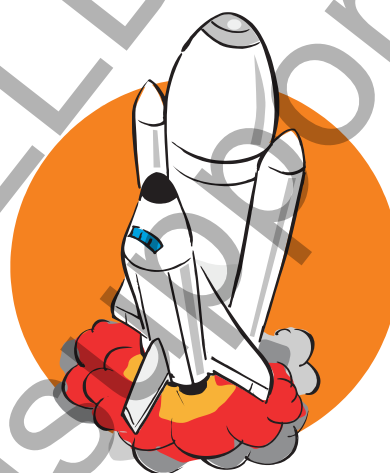

Cross out the wrong word.

- The **storm** finally  to weaken.
- Science** often  with creativity.
- Our support  early in the **process**.
- She usually  with a **fairy** tale.
- Our **shows**  at half past eight.
- Most **lessons**  with a presentation.

Use the orange words to fill in the puzzle.

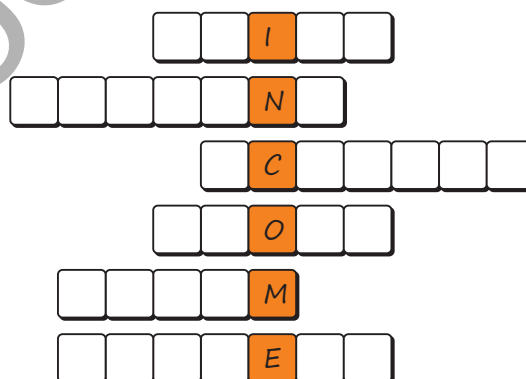

Use the words to complete the text.

Shuttle, missions, rocket, spacecraft

- The Space Shuttle was the world's first reusable \_\_\_\_\_.
- It took off like a \_\_\_\_\_, but landed like a glider.
- The \_\_\_\_\_ was launched for the first time in 1981.
- It carried a crew and cargo and flew on more than 130 \_\_\_\_\_.

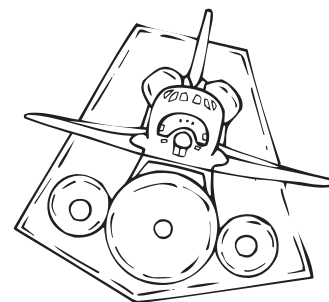

Voor een zelfstandig naamwoord schrijf je a of an.

- a bear, a house
- an elephant, an eye

Je gebruikt **a** als je een medeklinker (zoals een p) hoort.

Je gebruikt **an** als je een klinker (zoals een i) hoort.

Let dus goed op de beginklank van het woord.



### Exercise 1

Cross out the wrong word.

- 1 Paul is reading (a/an) old book.
- 2 We have (a/an) present for you!
- 3 She has (a/an) aunt in Ireland.
- 4 Sue eats (a/an) orange every day.
- 5 Do you have (a/an) pencil for me?
- 6 This is (a/an) English TV channel.
- 7 You're wearing (a/an) beautiful dress.
- 8 My car can drive 150 miles (a/an) hour.

### Exercise 2

Draw a line to all words with 'an'.

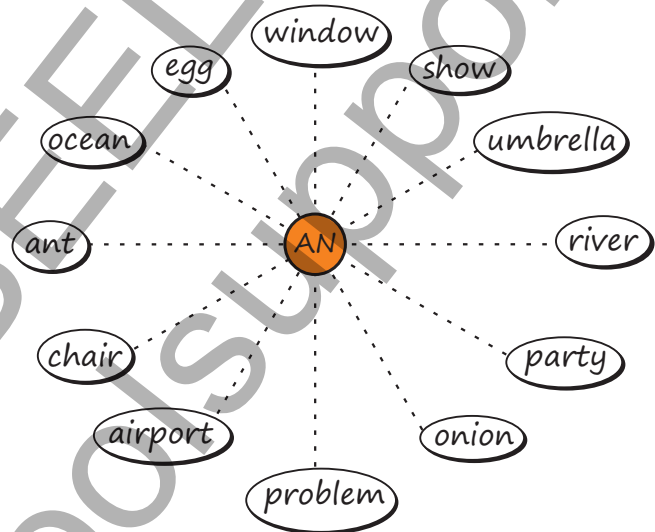

### Exercise 3

A or an? Tick the right box.



- |   |                                       |
|---|---------------------------------------|
| 1 <input checked="" type="checkbox"/> a sport | 9 <input type="checkbox"/> a ear      |
| 2 <input type="checkbox"/> an uniform         | 10 <input type="checkbox"/> a shoe    |
| 3 <input type="checkbox"/> an actor           | 11 <input type="checkbox"/> a idea    |
| 4 <input type="checkbox"/> a area             | 12 <input type="checkbox"/> an flower |
| 5 <input type="checkbox"/> an exam            | 13 <input type="checkbox"/> a report  |
| 6 <input type="checkbox"/> a shirt            | 14 <input type="checkbox"/> an apple  |
| 7 <input type="checkbox"/> a Irishman         | 15 <input type="checkbox"/> a drink   |
| 8 <input type="checkbox"/> an accident        | 16 <input type="checkbox"/> an year   |

### Exercise 4

Cross out the wrong word.

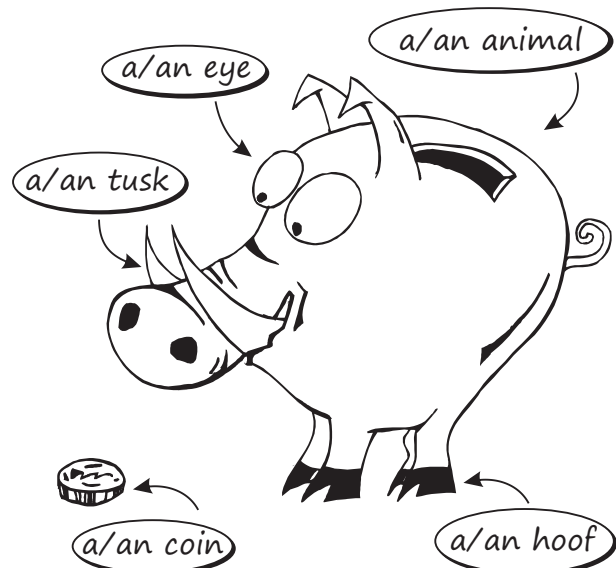



A sphinx, B river, C amphora, D mummy

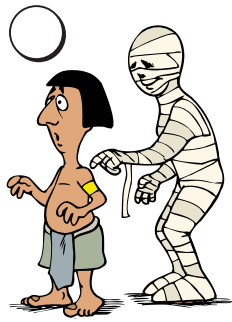
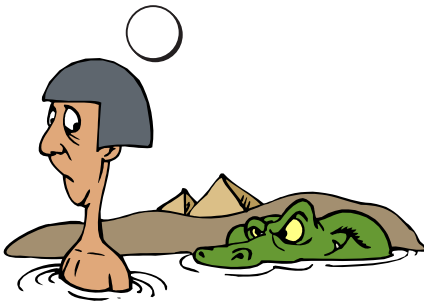

Match the words with their descriptions.

- |           |                            |  |
|-----------|----------------------------|--|
| 1 amphora | <input type="checkbox"/> M | E an old stone building with four sloping sides                      |
| 2 pyramid | <input type="checkbox"/>   | N a place in a desert where there is water and plants and trees grow |
| 3 desert  | <input type="checkbox"/>   | M a tall clay container or jar for oil or wine, etc.                 |
| 4 temple  | <input type="checkbox"/>   | I a grave where a dead person is buried                              |
| 5 tomb    | <input type="checkbox"/>   | G a dead body wrapped in long narrow pieces of cloth                 |
| 6 oasis   | <input type="checkbox"/>   | N a building used for the worship of a god                           |
| 7 mummy   | <input type="checkbox"/>   | A a large area of land where it is always very dry                   |

Underline the words that rhyme.

there once was a mummy  
lonely and cold  
he woke up and said  
I must be very old  
high time to get up  
let's do it today  
he opened his tomb  
and walked away

Use the seven words to fill in the puzzle.

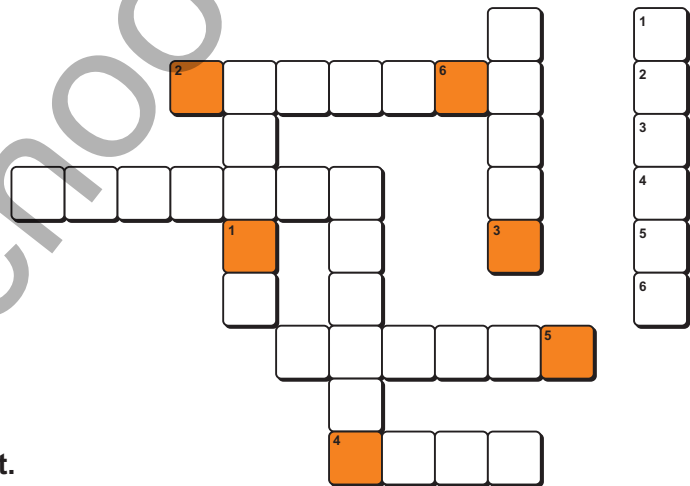

Use the words in the box to complete the text.

around, built, years, largest, slaves

- There are \_\_\_\_\_ 138 Egyptian pyramids.
- The \_\_\_\_\_ is called the Great Pyramid of Giza.
- When it was first \_\_\_\_\_ it was over 480 feet tall!
- Thousands of \_\_\_\_\_ were used to cut up the large blocks.
- It took at least 20,000 workers over 23 \_\_\_\_\_.

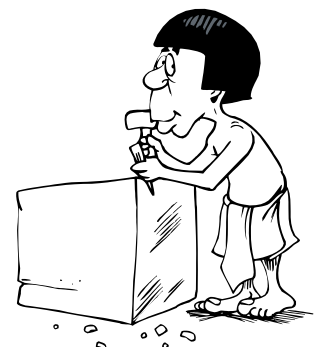





Practise this dialogue with a classmate.

Wouldn't you like to go to Egypt?

On a holiday? Of course not. Too hot for me.

There's so much to see there.

Yeah, lots of rocks and sand you mean.

I'm thinking of the pyramids.

I'm thinking of all the tourists there.

Three-thousand-year-old mummies.

Why does that interest you?

You know I love history. It's so exciting!

What about the real world? Here and now?

We can learn so much from the past.

Don't forget the present and the future.

What's so important about them?

Well, we have a biology test tomorrow.

A test? I didn't know that.

Time to get back to the real world. School!

Talk about the pictures.

- 1 Take a look at these four pictures.
- 2 What do you see?
- 3 Tell each other what is happening.

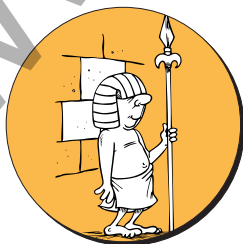

Write these seven words in alphabetical order.

company, careful, cloud, calendar, colour, clever, cheek

1	kalender	<input type="text"/>	<input type="text"/>	<input type="text"/>	<input type="text"/>	<input type="text"/>	<input type="text"/>	<input type="text"/>	<input type="text"/>	1
2	voorzichtig	<input type="text"/>	<input type="text"/>	<input type="text"/>	<input type="text"/>	<input type="text"/>	<input type="text"/>	<input type="text"/>	<input type="text"/>	2
3	wang	<input type="text"/>	<input type="text"/>	<input type="text"/>	<input type="text"/>	<input type="text"/>	<input type="text"/>	<input type="text"/>	<input type="text"/>	3
4	slim	<input type="text"/>	<input type="text"/>	<input type="text"/>	<input type="text"/>	<input type="text"/>	<input type="text"/>	<input type="text"/>	<input type="text"/>	4
5	wolk	<input type="text"/>	<input type="text"/>	<input type="text"/>	<input type="text"/>	<input type="text"/>	<input type="text"/>	<input type="text"/>	<input type="text"/>	5
6	kleur	<input type="text"/>	<input type="text"/>	<input type="text"/>	<input type="text"/>	<input type="text"/>	<input type="text"/>	<input type="text"/>	<input type="text"/>	6
7	bedrijf	<input type="text"/>	<input type="text"/>	<input type="text"/>	<input type="text"/>	<input type="text"/>	<input type="text"/>	<input type="text"/>	<input type="text"/>	7



Write the orange words in the correct sentence.

- 1 A dark \_\_\_\_\_ blocked the bright sunshine.
- 2 I marked your birthday on the \_\_\_\_\_.
- 3 Do you know what her favourite \_\_\_\_\_ is?
- 4 She kissed her boyfriend on his left \_\_\_\_\_.
- 5 We started a bicycle \_\_\_\_\_ last year.
- 6 He is \_\_\_\_\_ enough to solve the problem.
- 7 Always be \_\_\_\_\_ when you cross a road.

Match the words with their translations.

- |   |          |                       |                       |         |
|---|----------|-----------------------|-----------------------|---------|
| 1 | coast    | <input type="radio"/> | <input type="radio"/> | camping |
| 2 | coffee   | <input type="radio"/> | <input type="radio"/> | kust    |
| 3 | comb     | <input type="radio"/> | <input type="radio"/> | stad    |
| 4 | city     | <input type="radio"/> | <input type="radio"/> | kip     |
| 5 | climber  | <input type="radio"/> | <input type="radio"/> | kam     |
| 6 | chicken  | <input type="radio"/> | <input type="radio"/> | klimmer |
| 7 | campsite | <input type="radio"/> | <input type="radio"/> | koffie  |

Use the words in the box to complete the text.

rise, droplets, millions, water, reflect

- 1 Tiny droplets of \_\_\_\_\_ in the air rise with warm air.
- 2 As they \_\_\_\_\_, they get cooler.
- 3 They combine with other \_\_\_\_\_ to form clouds.
- 4 Clouds are white because they \_\_\_\_\_ sunlight.
- 5 They can contain \_\_\_\_\_ of tons of water.

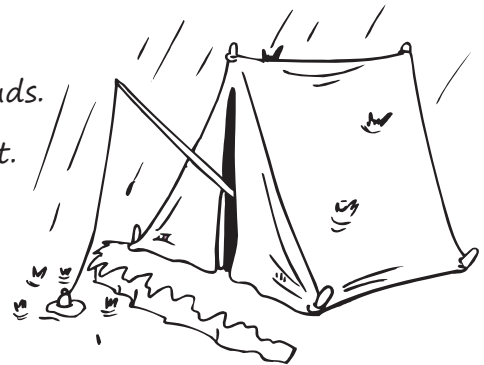

# A RAINY DAY

## Find the right translation and connect the dots.

- |                         |   |                   |   |                 |
|-------------------------|---|-------------------|---|-----------------|
| 1 ik vind               | ↔ | I find            | ● | ● hij vindt     |
| 2 jij/u vindt           | ↔ | you find          | ● | ● ik vind       |
| 3 hij/zij/het vindt     | ↔ | he/she/it finds   | ● | ● u vond        |
| 4 wij/jullie/zij vinden | ↔ | we/you/they find  | ● | ● jij vindt     |
| 5 ik/jij/u/hij/het vond | ↔ | I/you/he/it found | ● | ● wij vonden    |
| 6 wij/jullie/zij vonden | ↔ | we/you/they found | ● | ● jullie vinden |

## Use the words to complete the sentences.

felt, talked, sold, was, had, found

- They \_\_\_\_\_ about solar energy.
- She \_\_\_\_\_ an injury to her neck.
- He \_\_\_\_\_ at the reception desk.
- We \_\_\_\_\_ my old guitar last week.
- She \_\_\_\_\_ a treasure underwater.
- I suddenly \_\_\_\_\_ dizzy and sat down.



## Cross out the wrong word.

- Jessica **find / finds** that story hard to **believe**.
- We both **find / finds** this trip **exciting**.
- Our manager **find / finds** your ideas **excellent**.
- She **find / finds** these **comedies** very funny.
- My brother **find / finds** this **game** too difficult.
- Aron **find / finds** his new job very **interesting**.

## Use the orange words to fill in the puzzle.

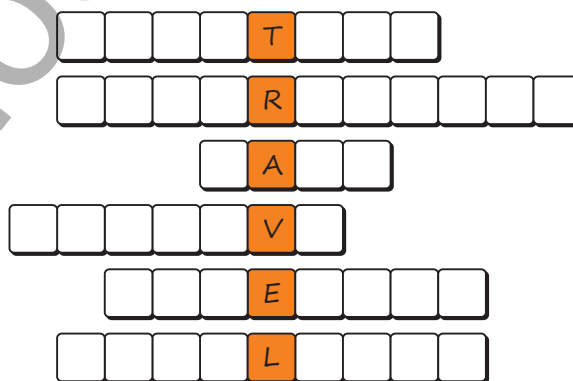

## Use the words to complete the text.

famous, throne, treasures, tomb

- King Tut was a \_\_\_\_\_ Egyptian ruler.
- His \_\_\_\_\_ was discovered by British archaeologists.
- The \_\_\_\_\_ included a golden mask and a crown.
- There were also paintings, a golden \_\_\_\_\_ and his sandals.



1 Write two words for each picture.



  

2 Write down eight words that start with the letter T

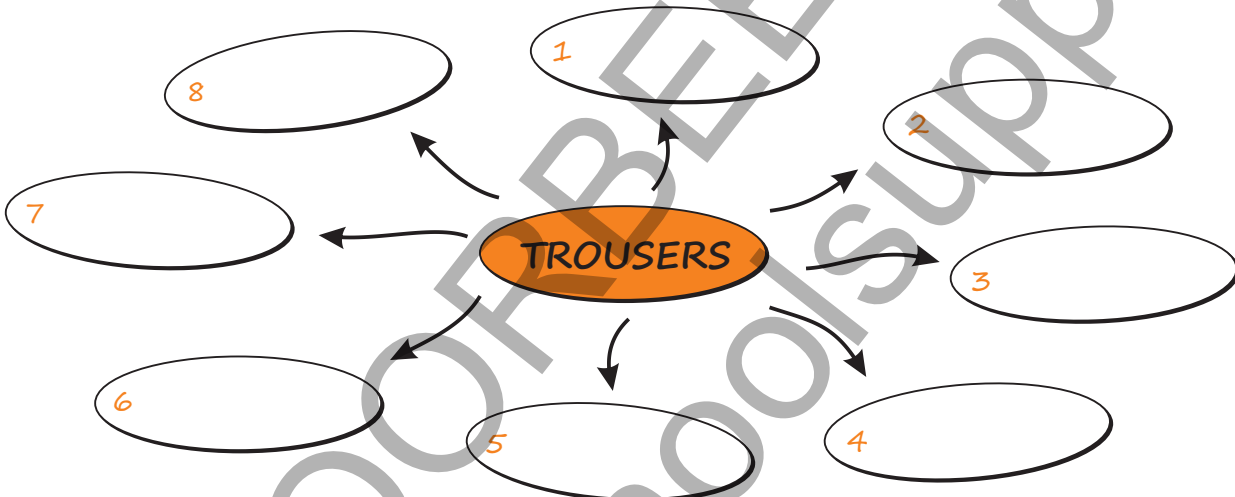

3 Use the words in the box to make a question with do or does.

1 every, Max, swim, does, Saturday

4 he, does, brother, your, like

.....

.....

2 office, does, in, Lucie, work, an

5 to, have, help, they, do, time

.....

.....

3 know, all, do, answers, the, you

6 next, you, live, does, to, Ella

.....

.....



1 Match the words with their descriptions. (6 points)

- |           |                          |  |
|-----------|--------------------------|--|
| 1 desert  | <input type="checkbox"/> | A a large boat that carries passengers or cargo    |
| 2 cloud   | <input type="checkbox"/> | B when the sea level on a coast becomes lower      |
| 3 dune    | <input type="checkbox"/> | C a white or grey mass in the sky                  |
| 4 ship    | <input type="checkbox"/> | D a hill made of sand near the sea                 |
| 5 ebb     | <input type="checkbox"/> | E an old, stone building with four sloping sides   |
| 6 pyramid | <input type="checkbox"/> | F a large area of land where it is always very dry |

2 Tick the box if the combination is right. (8 points)

- |               |                          |            |                          |
|---------------|--------------------------|------------|--------------------------|
| 1 a city      | <input type="checkbox"/> | 5 an hour  | <input type="checkbox"/> |
| 2 an officer  | <input type="checkbox"/> | 6 a idea   | <input type="checkbox"/> |
| 3 an question | <input type="checkbox"/> | 7 an ear   | <input type="checkbox"/> |
| 4 a operation | <input type="checkbox"/> | 8 a orange | <input type="checkbox"/> |

<input checked="" type="checkbox"/>	exercise 1	<input type="checkbox"/>	points
<input checked="" type="checkbox"/>	exercise 2	<input type="checkbox"/>	points
<input checked="" type="checkbox"/>	exercise 3	<input type="checkbox"/>	points
<input checked="" type="checkbox"/>	Total	<input type="checkbox"/>	points

3 Translate the words and phrases. (10 points)

- |           |   |       |                  |   |       |
|-----------|---|-------|------------------|---|-------|
| 1 cheek   | → | _____ | 6 wij beginnen   | → | _____ |
| 2 award   | → | _____ | 7 hij begint     | → | _____ |
| 3 clever  | → | _____ | 8 het begon      | → | _____ |
| 4 afraid  | → | _____ | 9 jij vindt      | → | _____ |
| 5 careful | → | _____ | 10 jullie vonden | → | _____ |

What comes next? Check it out.

Translate the words and phrases. (10 points)

- |          |   |       |                  |   |       |
|----------|---|-------|------------------|---|-------|
| 1 corner | → | _____ | 6 zij steelt     | → | _____ |
| 2 dizzy  | → | _____ | 7 jullie stelen  | → | _____ |
| 3 peach  | → | _____ | 8 ik ontmoet     | → | _____ |
| 4 dirty  | → | _____ | 9 hij ontmoet    | → | _____ |
| 5 grapes | → | _____ | 10 wij ontmoeten | → | _____ |

14-16 points: okay  
17-20 points: good  
21-24 points: excellent

5-6 points: okay  
7-8 points: good  
9-10 points: excellent



A cheese, B pancakes, C berries, D fries

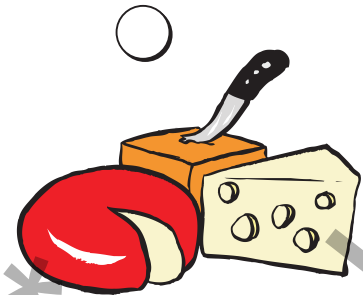
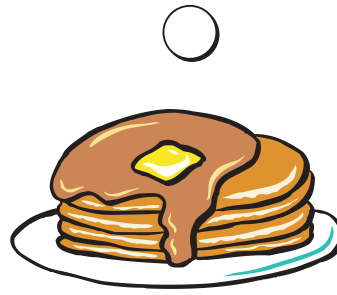
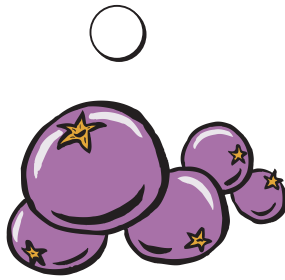
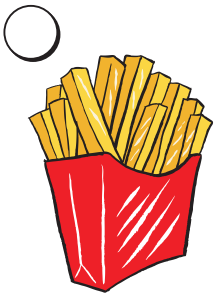

Match the words with their descriptions.

- |   |           |                          |   |   |  |
|---|-----------|--------------------------|---|---|--|
| 1 | bake      | <input type="checkbox"/> | S | O | the list of foods and drinks served in a restaurant        |
| 2 | cutlery   | <input type="checkbox"/> | S | S | to cook by dry heat in an oven                             |
| 3 | dessert   | <input type="checkbox"/> | F | F | the taste of food or drink                                 |
| 4 | flavour   | <input type="checkbox"/> | D | D | instructions for cooking a dish or a meal                  |
| 5 | junk food | <input type="checkbox"/> | A | A | sweet food eaten at the end of a meal                      |
| 6 | menu      | <input type="checkbox"/> | E | E | knives, forks, and spoons used for eating                  |
| 7 | recipe    | <input type="checkbox"/> | O | O | unhealthy food because of all the fat, salt or sugar in it |

Underline the words that rhyme.

*mix the butter,  
sugar, flour  
bake that cake  
in half an hour  
read the recipe  
carefully through  
surprise your guests  
with what you can do!*

Use the seven words to fill in the puzzle.

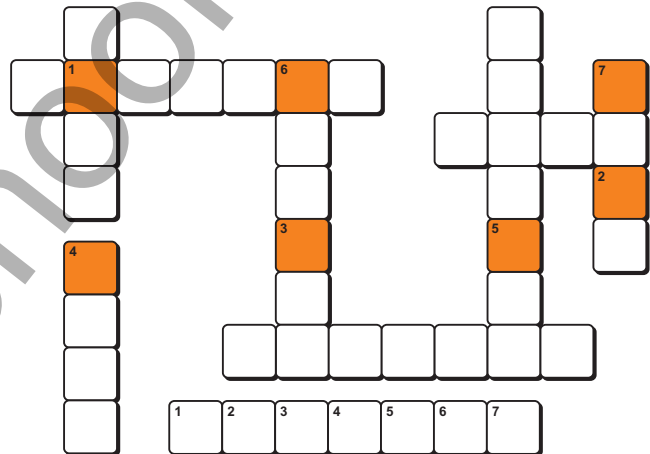

Use the words in the box to complete the text.

cooking, food, fire, butter, oven

- There are several different ways to cook \_\_\_\_\_.
- We boil food by \_\_\_\_\_ it in water.
- We fry food by cooking it in hot \_\_\_\_\_, fat or oil.
- We bake food by keeping it hot in an \_\_\_\_\_.
- We roast or grill food by holding it over a hot \_\_\_\_\_.

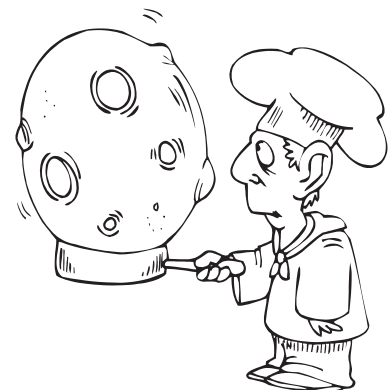



### Exercise 1 - Interview

Ask a classmate what he or she likes best.

- 1 Broccoli, lettuce or carrots?
- 2 Potatoes, rice or macaroni?
- 3 Pizza, pancakes or crisps?
- 4 Cookies, donuts or brownies.
- 5 A banana, an apple or a kiwi?
- 6 Cheese, jam or peanut butter?
- 7 Yoghurt, ice or fruit?
- 8 Water, milk or lemonade?



### Exercise 2 - Can you guess who I am?

Work together and try to solve these three riddles.

1

I'm made from nectar.  
I'm very sticky.  
I taste really sweet.  
I'm made by many bees.

2

I'm sometimes decorated.  
Yes, you can paint me.  
Chickens lay me.  
My body has a shell.

3

You have to peel me first.  
Then you can eat me.  
I'm often turned into juice.  
My name is also a colour.

### Exercise 3 - Talk about the pictures.

- 1 Take a look at these four pictures.
- 2 What do you see?
- 3 What are they doing?
- 4 Do you know the names of these vegetables?



Write these seven words in alphabetical order.

corner, crowd, collar, country, curtain, couple, crime

1	halsband	<input type="text"/>	<input type="text"/>	1
2	hoek	<input type="text"/>	<input type="text"/>	2
3	land	<input type="text"/>	<input type="text"/>	3
4	paar	<input type="text"/>	<input type="text"/>	4
5	misdaad	<input type="text"/>	<input type="text"/>	5
6	menigte	<input type="text"/>	<input type="text"/>	6
7	gordijn	<input type="text"/>	<input type="text"/>	7



Write the orange words in the correct sentence.

- I have a \_\_\_\_\_ of good friends.
- San Marino is a small \_\_\_\_\_ in Italy.
- His only \_\_\_\_\_ was stealing cars.
- I opened the \_\_\_\_\_ to look outside.
- There was a \_\_\_\_\_ of about 8000 people.
- Our dog has a \_\_\_\_\_ and an ID tag.
- The bus stop is just around the \_\_\_\_\_.

Match the words with their translations.

to chat	1 kiezen	6 controleren
3 sluiten	to cycle	to change
5 fietsen	to check	4 kletsen
to choose	2 veranderen	to close

1 C 2 3 4 5 6

Use the words in the box to complete the text.

takes, stop, wishlist, cash, people

- Thieves work fast: the average burglary \_\_\_\_\_ 8-10 minutes.
- They usually have a \_\_\_\_\_ of easy-to-sell items.
- Most \_\_\_\_\_ keep valuables in their bedrooms.
- Many burglars make that their first \_\_\_\_\_.
- They look for \_\_\_\_\_, laptops, tablets and jewelry.



# A HOUSE BREAK-IN



Find the right translation and connect the dots.

- |   |                            |    |                  |   |                  |
|---|----------------------------|----|------------------|---|------------------|
| 1 | ik ontmoet                 | ←→ | I meet           | ● | u ontmoet        |
| 2 | jij/u ontmoet              | ←→ | you meet         | ● | hij ontmoette    |
| 3 | hij/zij/het ontmoet        | ←→ | he/she/it meets  | ● | jullie ontmoeten |
| 4 | wij/jullie/zij ontmoeten   | ←→ | we/you/they meet | ● | ik ontmoet       |
| 5 | ik/jij/u/hij/het ontmoette | ←→ | I/you/he/it met  | ● | wij ontmoetten   |
| 6 | wij/jullie/zij ontmoetten  | ←→ | we/you/they met  | ● | zij ontmoet      |

Use the words to complete the sentences.

met, saw, said, had, brought, forgot

- He \_\_\_\_\_ her some more tea.
- We \_\_\_\_\_ the race on television.
- She \_\_\_\_\_ to invite me to the party.
- They never \_\_\_\_\_ each other before.
- Chelsea \_\_\_\_\_ she was living in London.
- I \_\_\_\_\_ a great weekend with my friends.



Cross out the wrong word.

- He often meet / meets other **businessmen**.
- Most **groups** meet / meets twice a month.
- I meet / meets my clients in a **private** practice.
- We usually meet / meets every **Thursday**.
- Eva never meet / meets any **famous** people.
- The president meet / meets his **staff** every day.

Use the orange words to fill in the puzzle.

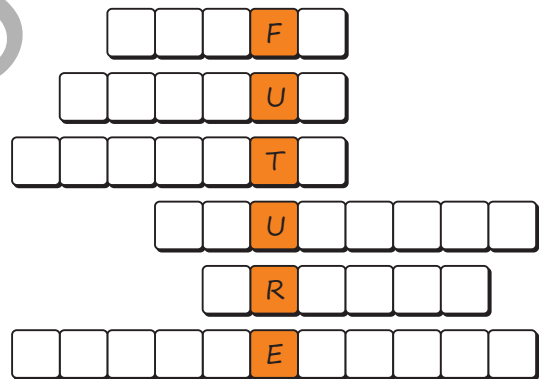

Use the words to complete the text.

West, deals, official, leaders

- The Oval Office is the \_\_\_\_\_ office of the president of the USA.
- It is located in the \_\_\_\_\_ Wing of the White House.
- In this office, the president \_\_\_\_\_ with all kinds of problems.
- Here, he also meets important \_\_\_\_\_ and his staff.



Je gebruikt een bezittelijk voornaamwoord om aan te geven van wie iets is.

- mijn kamer → my room
- jouw fiets → your bicycle
- ons avontuur → our adventure



Voor jouw, uw, en jullie gebruik je 'your'.

- mijn → my
- jouw/uw → your
- zijn → his
- haar → her
- ons/onze → our
- jullie → your
- hun → their

### Exercise 1

Fill in the right word.

- 1 What happened to (*mijn*) \_\_\_\_\_ suitcase?
- 2 I haven't got (*uw*) \_\_\_\_\_ address.
- 3 They use (*hun*) \_\_\_\_\_ own tools.
- 4 Did she do (*haar*) \_\_\_\_\_ homework?
- 5 There was a fox in (*onze*) \_\_\_\_\_ garden.
- 6 (*Zijn*) \_\_\_\_\_ favourite flavour is vanilla.

### Exercise 2

Cross out the wrong answer.

- 1 hun idee ●●●●●  her /  their idea
- 2 ons werk ●●●●●  our /  his work
- 3 uw vraag ●●●●●  your /  our question
- 4 zijn sleutel ●●●●●  my /  his key
- 5 jullie hulp ●●●●●  your /  our help

### Exercise 3

Connect the right dots with a line.

- |                   |                |
|-------------------|----------------|
| 1 onze fouten ●   | ● your answer  |
| 2 uw geld ●       | ● her shoes    |
| 3 jouw antwoord ● | ● my family    |
| 4 mijn familie ●  | ● your money   |
| 5 haar schoenen ● | ● our mistakes |

### Exercise 4

Fill in: my, your, our, her, their

- 1 She has an orange. → It's \_\_\_\_\_ orange.
- 2 They have a car. → It's \_\_\_\_\_ car.
- 3 I have a ticket. → It's \_\_\_\_\_ ticket.
- 4 We have a brother. → It's \_\_\_\_\_ brother.
- 5 You have a dog. → It's \_\_\_\_\_ dog.

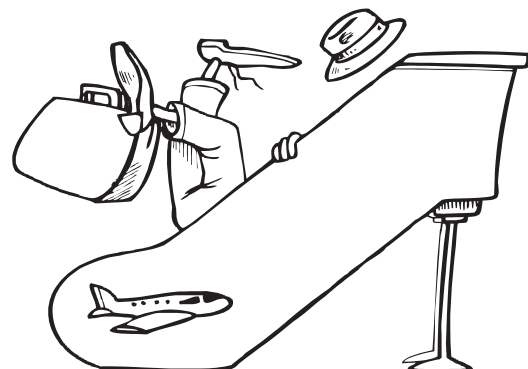



A bread, B grapes, C cake, D peach

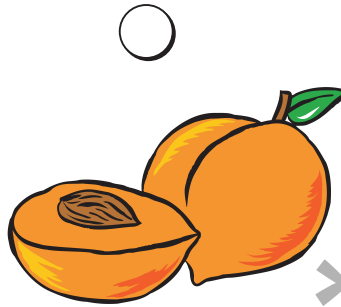
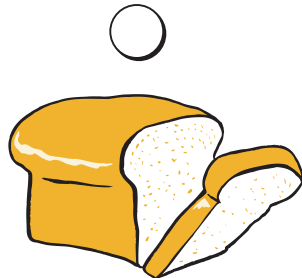
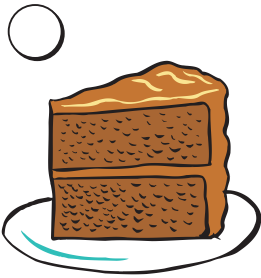

Match the words with their descriptions.

- |             |                            |   |
|-------------|----------------------------|---|
| 1 breakfast | <input type="checkbox"/> S | H a large fruit like a nut with a thick, hard, brown shell            |
| 2 potato    | <input type="checkbox"/>   | N a smooth, thick liquid made from plants and used for cooking        |
| 3 omelette  | <input type="checkbox"/>   | P a white vegetable with brown skin that grows under the ground       |
| 4 oil       | <input type="checkbox"/>   | C eating only certain foods to lose weight, or to improve your health |
| 5 spices    | <input type="checkbox"/>   | S the meal you have in the morning                                    |
| 6 diet      | <input type="checkbox"/>   | I eggs mixed together and cooked in hot fat                           |
| 7 coconut   | <input type="checkbox"/>   | A a type of powder that you put into food to give it a special taste  |

Underline the words that rhyme.

lay the table  
do it right  
all my friends  
are coming tonight  
potatoes, veggies  
and pudding too  
so out of my kitchen  
I have work to do

Use the seven words to fill in the puzzle.

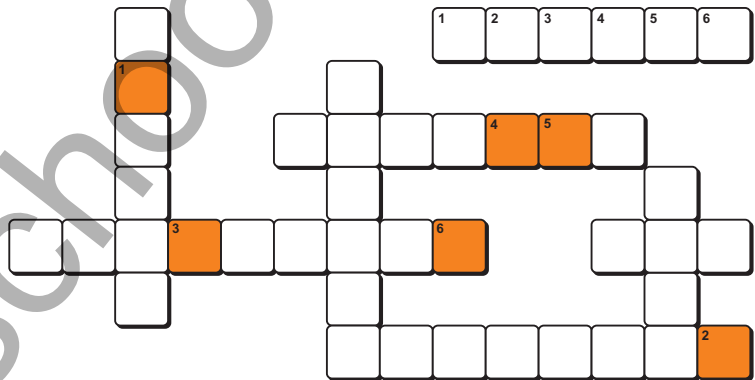

Use the words in the box to complete the text.

water, sandwiches, oven, darker, baked

- Bread is a type of \_\_\_\_\_ food.
- It is mainly made from dough (flour and \_\_\_\_\_).
- Bread is often baked in an \_\_\_\_\_.
- It can be toasted or used to make \_\_\_\_\_.
- Flour made from the whole grain gives \_\_\_\_\_ bread.





Practise this dialogue with a classmate.

Breakfast, lunch or dinner time.

I just want to start this rhyme.

When I'm hungry, that is true,

I eat anything. What about you?

Pasta, pudding, cheese and bread.

Jam and jelly, chocolate spread.

Lemons, toffees, cauliflower.

I can eat at any hour.

Milkshakes or a chicken wing.

I keep eating, that's the thing.

Eggs and muffins, spinach, ice.

Salads, walnuts, melons, rice.

Sour, salty, bitter, sweet.

There is always time to eat.

Yummie, yummie, that looks great.

All that food, I just can't wait!

Talk about the pictures.

- 1 Take a look at these four pictures.
- 2 What do you see?
- 3 Tell each other what is happening.



Write these seven words in alphabetical order.

dizzy, decision, doubt, dirty, duty, disaster, debt

1	schuld	<input type="text"/>	<input type="text"/>
2	beslissing	<input type="text"/>	<input type="text"/>
3	vies	<input type="text"/>	<input type="text"/>
4	ramp	<input type="text"/>	<input type="text"/>
5	duizelig	<input type="text"/>	<input type="text"/>
6	twijfel	<input type="text"/>	<input type="text"/>
7	plicht	<input type="text"/>	<input type="text"/>



Write the orange words in the correct sentence.

Match the words with their translations.

- 1 I was \_\_\_\_\_ after the roller-coaster ride.
- 2 It is my \_\_\_\_\_ to guard people's safety.
- 3 He has a \_\_\_\_\_ of around £1800.
- 4 It wasn't easy to make the right \_\_\_\_\_.
- 5 There was \_\_\_\_\_ about her real identity.
- 6 The hotel room was \_\_\_\_\_ and smelly.
- 7 An earthquake is a natural \_\_\_\_\_.

- |               |                       |                       |           |
|---------------|-----------------------|-----------------------|-----------|
| 1 to do       | <input type="radio"/> | <input type="radio"/> | drinken   |
| 2 to drive    | <input type="radio"/> | <input type="radio"/> | drogen    |
| 3 to dream    | <input type="radio"/> | <input type="radio"/> | doen      |
| 4 to dive     | <input type="radio"/> | <input type="radio"/> | dromen    |
| 5 to drink    | <input type="radio"/> | <input type="radio"/> | ontdekken |
| 6 to dry      | <input type="radio"/> | <input type="radio"/> | rijden    |
| 7 to discover | <input type="radio"/> | <input type="radio"/> | duiken    |

Use the words in the box to complete the text.

down, wood, number, modern, ride

- 1 The roller coaster is a kind of amusement \_\_\_\_\_.
- 2 It has a \_\_\_\_\_ of carriages that travel on a set of tracks.
- 3 The track has hills and valleys (parts that go up and \_\_\_\_\_).
- 4 It can be made from \_\_\_\_\_ or steel.
- 5 The first \_\_\_\_\_ steel roller coaster opened in 1959.



# THE WORLD IS SPINNING

Find the right translation and connect the dots.

- |                         |    |                   |   |                 |
|-------------------------|----|-------------------|---|-----------------|
| 1 ik steel              | ←→ | I steal           | ● | ● jullie stelen |
| 2 jij/u steelt          | ←→ | you steal         | ● | ● zij steelt    |
| 3 hij/zij/het steelt    | ←→ | he/she/it steals  | ● | ● ik steel      |
| 4 wij/jullie/zij stelen | ←→ | we/you/they steal | ● | ● zij stalen    |
| 5 ik/jij/u/hij/het stal | ←→ | I/you/he/it stole | ● | ● jij steelt    |
| 6 wij/jullie/zij stalen | ←→ | we/you/they stole | ● | ● hij stal      |

Use the words to complete the sentences.

found, stole, felt, ran, meant, sold

- Connor usually \_\_\_\_\_ for at least an hour.
- I \_\_\_\_\_ an antique clock for £13,500.
- Amy \_\_\_\_\_ it difficult to ask for help.
- They \_\_\_\_\_ millions from European banks.
- We never \_\_\_\_\_ to hurt anyone.
- The water \_\_\_\_\_ nice in the heat of the day.

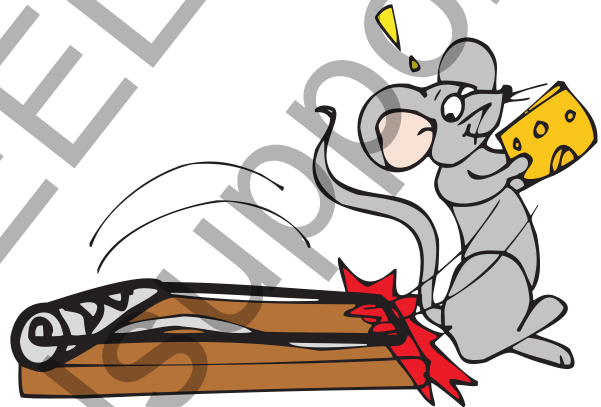

Cross out the wrong word.

- Joe steal / steals cars in **parking** lots.
- She never steal / steals from **travelers**.
- I sometimes steal / steals from other **criminals**.
- Liam usually steal / steals **motorcycles**.
- Teenage shoplifters often steal / steals on **impulse**.
- He only steal / steals at night or **anywhere** dark.

Use the orange words to fill in the puzzle.

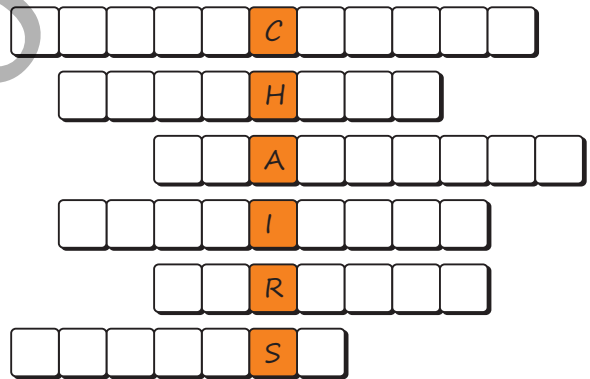

Use the words to complete the text.

were, signal, robbed, bank

- On August 8, 1963, 15 thieves \_\_\_\_\_ a Royal mail train.
- They stopped the train by changing a \_\_\_\_\_ from green to red.
- The thieves stole used \_\_\_\_\_ notes worth £2.3 million.
- 12 of the 15 robbers \_\_\_\_\_ later caught, convicted and jailed.



### 1 Read the text and answer the questions.

- 1 Ants live in colonies, just like bees.
- 2 Queen ants can live up to 30 years and lay thousands of eggs.
- 3 The other female ants are worker ants.
- 4 They build the ant hill, find food and even act as soldier ants.
- 5 They bring leaves, crumbs and dead insects back to the colony to eat.
- 6 If the queen dies, the colony can only survive a few months.
- 7 Ants 'hear' by feeling vibrations in the ground through their feet.
- 8 An ant can lift 20 times its own body weight. That's like you lifting a car!

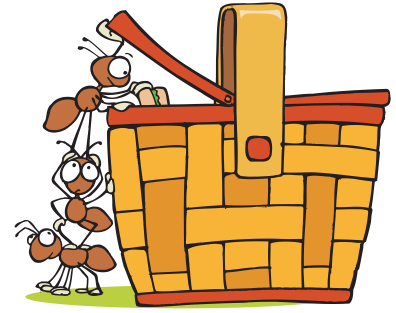

### Questions

- 1 Met welke dieren worden mieren vergeleken?
- 2 Wat wordt over de koningin gezegd in zin 2?
- 3 Welke taken worden door werkmieren gedaan?
- 4 Kunnen mieren horen?
- 5 Wat gebeurt er als de koningin dood gaat?

### 2 Translate these three words into Dutch. Use a dictionary.

- crumb ..... ● vibration ..... ● weight .....

### 3 Write a short sentence for each picture.

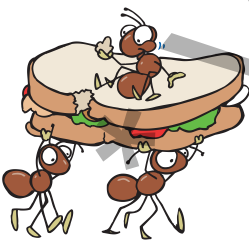







**1 Match the words with their descriptions. (6 points)**

- |             |                          |  |
|-------------|--------------------------|--|
| 1 dirty     | <input type="checkbox"/> | A the list of foods and drinks served in a restaurant      |
| 2 coconut   | <input type="checkbox"/> | B when something is not clean                              |
| 3 menu      | <input type="checkbox"/> | C a large fruit like a nut with a thick, hard, brown shell |
| 4 disaster  | <input type="checkbox"/> | D the first meal of the day                                |
| 5 breakfast | <input type="checkbox"/> | E instructions for cooking a dish or a meal                |
| 6 recipe    | <input type="checkbox"/> | F an event such as an earthquake that causes great damage  |

**2 Translate the words in brackets. (8 points)**

- |                     |                       |
|---------------------|-----------------------|
| 1 (onze) car _____  | 5 (jouw) nose _____   |
| 2 (uw) time _____   | 6 (zijn) money _____  |
| 3 (mijn) coat _____ | 7 (haar) idea _____   |
| 4 (hun) bags _____  | 8 (jullie) work _____ |

✓ exercise 1	<input type="checkbox"/>	points
✓ exercise 2	<input type="checkbox"/>	points
✓ exercise 3	<input type="checkbox"/>	points
✓ Total	<input type="checkbox"/>	points

14-16 points: okay

17-20 points: good

21-24 points: excellent

**3 Translate the words and phrases. (10 points)**

- |                   |                          |
|-------------------|--------------------------|
| 1 bread → _____   | 6 jij ontmoet → _____    |
| 2 country → _____ | 7 zij ontmoet → _____    |
| 3 doubts → _____  | 8 ik ontmoette → _____   |
| 4 dizzy → _____   | 9 hij steelt → _____     |
| 5 potato → _____  | 10 jullie stelen → _____ |

**What comes next? Check it out.****Translate the words and phrases. (10 points)**

- |                   |                       |
|-------------------|-----------------------|
| 1 gate → _____    | 6 u vliegt → _____    |
| 2 sledge → _____  | 7 wij vliegen → _____ |
| 3 glue → _____    | 8 zij vliegt → _____  |
| 4 guilty → _____  | 9 ik gaf → _____      |
| 5 freedom → _____ | 10 zij gaven → _____  |

5-6 points: okay

7-8 points: good

9-10 points: excellent



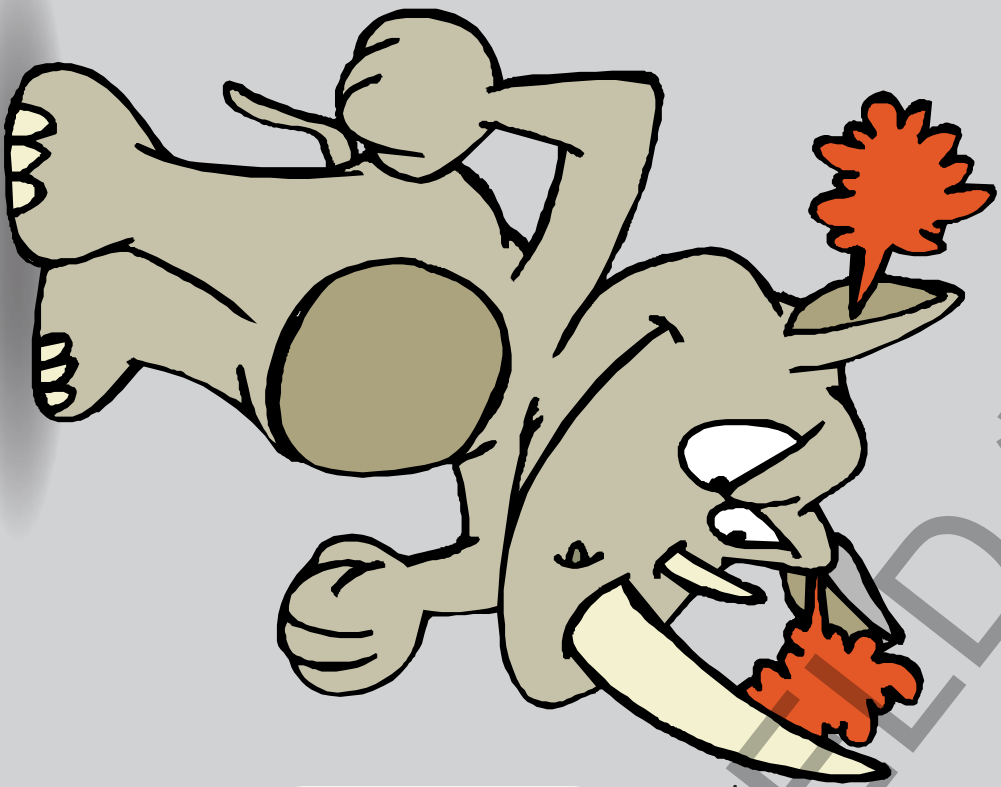

# diplooma

This diploma is presented to

**GET STARTED**

**DOWNLOAD COMPLETED #3**

Date

Signature

